

MERCURY SERIES

MER-500-14GC

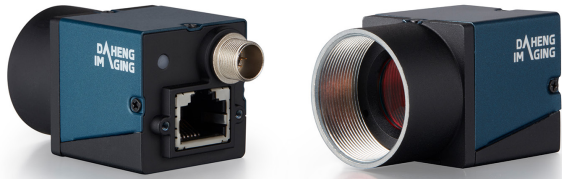

- Ultra small, light and robust
- 1/2.5" Rolling Shutter CMOS sensor
- Compatible with GenICam™ and GigE Vision®
- Gigabit Ethernet Interface
- 5 Megapixels
- 2 Programmable GPIOs
- Very attractive price

The MERCURY GigE series(MER-G) camera is DAHENG IMAGING's mature area scan industrial digital camera, featuring outstanding performance, compact design and extremely low noise.

The MER-500-14GC camera is a color GigE Vision camera with the Onsemi MT9P006 CMOS sensor. Thanks to the extremely compact (29mm × 29mm × 29mm), robust metal housings and locking screw connectors, the MERCURY cameras can secure the reliability of cameras deployed in harsh environments.

The MER-500-14GC camera has opto-isolated I/Os. The GPIOs give MER-G maximum flexibility to adapt to specific needs. The camera has an outstanding price/performance ratio.

The MERCURY family cameras are especially suitable for machine vision applications such as industrial inspection, medical, scientific research, education, security and so on.

Features

- GigE interface with 10-bit or 8-bit Bayer output
- Programmable ROI, increased frame rate with partial scan
- Gain, exposure and white balance programmable
- Support auto gain, auto exposure and auto white balance
- Support defect pixel correction
- Three acquisition controls: Continuous acquisition/Software trigger acquisition/External trigger acquisition
- Flash sync for firing external lights at precisely the moment when exposure is performed
- Adjustable packet-size and packet-delay, and reserved bandwidth
- Programmable LUTs and storable user sets
- Robust full metal housing and optional lockable devices
- Long cable lengths: up to 100 m (without any hubs, repeaters etc.)
- Compatible with GenICam™ and GigE Vision®, support a variety of 3rd-party software such as HALCON, MERLIC and LabVIEW
- Optimized software package for 32/64bit Windows, and support Linux, ARMv7 and ARMv8
- Multiple samples and easy-to-integrate SDKs for various programming tools
- Regulations: CE, RoHS, FCC, GenICam, GigE Vision

Performance Specifications

Model	MER-500-14GC
Interface	GigE
Resolution	2592(H) × 1944(V)
Frame rate	14 fps
Sensor	1/2.5" , Rolling Shutter Onsemi MT9P006 CMOS
Pixel size	2.2 μm × 2.2 μm
Pixel Bit Depth	8bit, 10bit
Spectrum	Color
Exposure time	36μs~1s

Optical Specifications

Lens mount	C-Mount (standard), CS-Mount (optional)
------------	---

Electrical Specifications

Power requirement	12 VDC via 8-Pin connector
I/Os	1 input / 1 output, 2 GPIOs
Data interface	RJ45
Power consumption	<2W @12V

Environmental Specifications

Operating temp.	0°C ~ +45°C
Storage temp.	-20°C ~ +70°C
Operating humidity	10% ~ 80%

Mechanical Specifications

Weight	60g
Dimensions	29(W)×29(H)×29(L)mm, w/o connectors

Technical Drawing

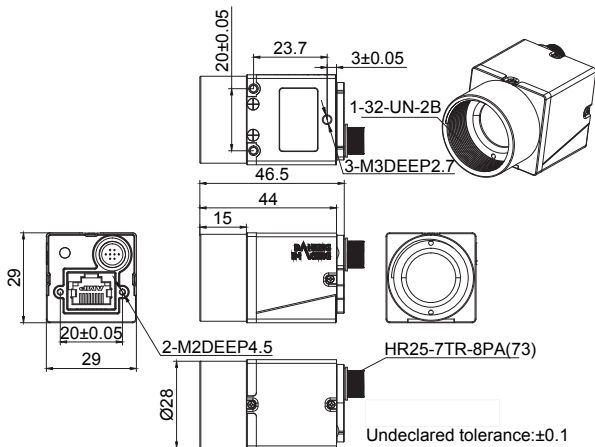

Units: mm

Spectral Response

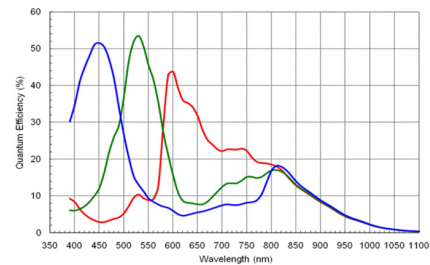

MER-500-14GC

China Daheng Group, Inc. Beijing Image Vision Technology Branch

12F Daheng Science & Technology Tower, No.3 Suzhou Street, Haidian District,

Beijing China, 100080

Tel: +86 10 82828878

E-mail: isales@daheng-imaging.com

For more information please visit : www.daheng-imaging.com/en

Specifications are subject to change without prior notice.

Copyright © 2021 China Daheng Group, Inc. Beijing Image Vision Technology Branch. All rights reserved.

October 14, 2021