

# VEN-161-61U3M/C

## VENUS Series 1.6MP CMOS USB3.0 Board Level Camera

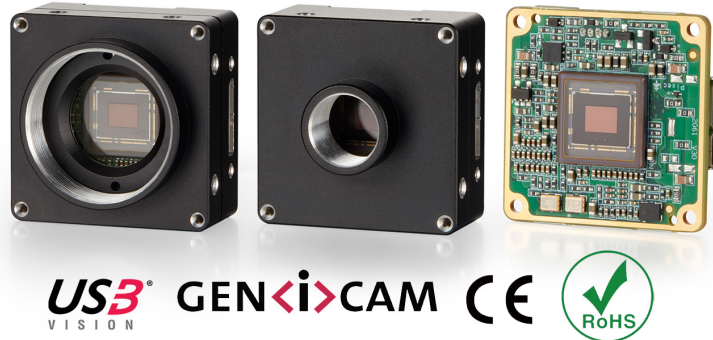

The VEN-161-61U3M/C camera is a monochrome/color all-in-one board level camera with the Sony IMX296 CMOS sensor. The VEN-161-61U3M/C provides four lens mount options: C-mount with housing, S-mount with housing, CS-mount with housing and No-mount (bare board). Thanks to the extremely compact housing and various mount options, the VEN-161-61U3M/C is more flexible in demanding space.

### Applications

Suitable for machine vision applications such as industrial inspection, medical, scientific research, education and so on.

### Features

- USB3.0(Micro-B) interface with 10-bit or 8-bit Mono/Bayer output
- Gain, auto gain, exposure and auto exposure
- Color model supports white balance, auto white balance and light source preset function
- User Set Control
- Support Reverse X/Y
- Support hardware trigger and software trigger
- 16KB data storage area for saving algorithm coefficients, parameter configuration, and so on

### Spectral Response

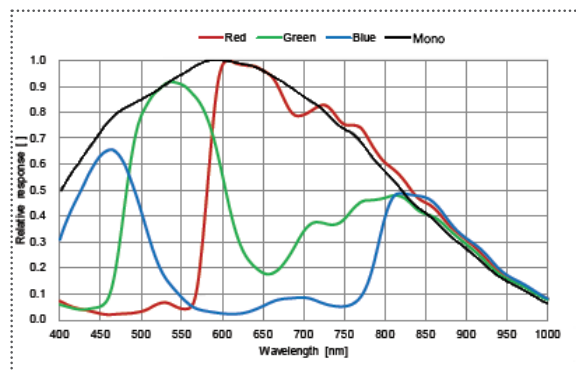

## Specifications

Model	VEN-161-61U3C	VEN-161-61U3M
Resolution	1440(H) × 1080(V)	
Sensor	Sony IMX296 Global shutter CMOS	
Sensor Format	1/2.9"	
Pixel Size	3.45μm × 3.45μm	
Frame Rate	61.2 fps	
ADC	10 bit	
Pixel Bit Depth	8 bit, 10 bit	
Mono/Color	Color	Mono
Pixel Formats	Bayer RG8 / Bayer RG10	Mono8 / Mono10
SNR	40.6 dB	
Exposure Time	Standard: 20μs ~ 1s, Actual Steps: 1 row period	
Gain	0dB ~ 24dB; Default: 0dB, Steps: 0.1dB	
Binning	-	
Decimation	-	
Synchronization	Hardware trigger, software trigger	
Acquisition Mode	Continuous, Software trigger, Hardware trigger	
Reverse X/Y	Reverse X/Y	
I/O Interface	1 input with opto-isolated, 1 programmable GPIO	
Data Interface	USB3.0 (Micro-B)	
Power Supply	Powered by USB3.0 bus	
Typical Power	1.21 W @ 5 VDC	
Operating Temp.	0° C ~ +45° C	
Storage Temp.	-20° C ~ +70° C	
Operating Humidity	10% ~ 80%	
Lens Mount	C / S / CS / No-mount	
Dimensions	35(W) × 35(H) × 15.8(L) mm (without lens adapter length) 32.5(W) × 32.5(H) × 8.12(L) mm (No-mount, PCB thickness is 1.6mm)	
Weight	32 g (C); 32 g (S); 31 g (CS); 7 g (No-mount)	
Software	3rd-party software such as HALCON, MERLIC and LabVIEW	
OS	32bit / 64bit Windows, Linux, Android, ARMv7, ARMv8	
Conformity	CE, RoHS, USB3.0 Vision®, GenICam®	

I/O Interface



Pin	Definition	Description
1	GND	GPIO GND
2	Line2	GPIO input/output
3	Line0+	Opto-isolated input +
4	Line0-	Opto-isolated input -

Technical Drawing

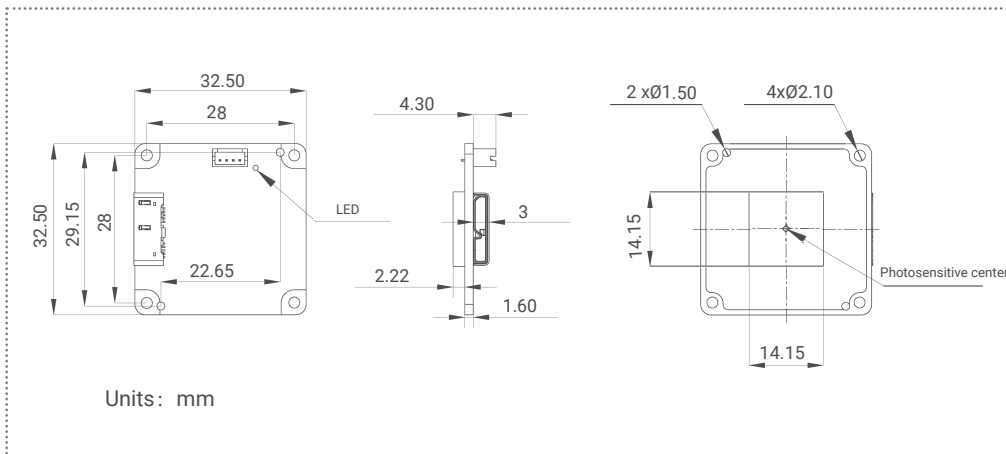

VEN-161-61U3M/C, No-mount

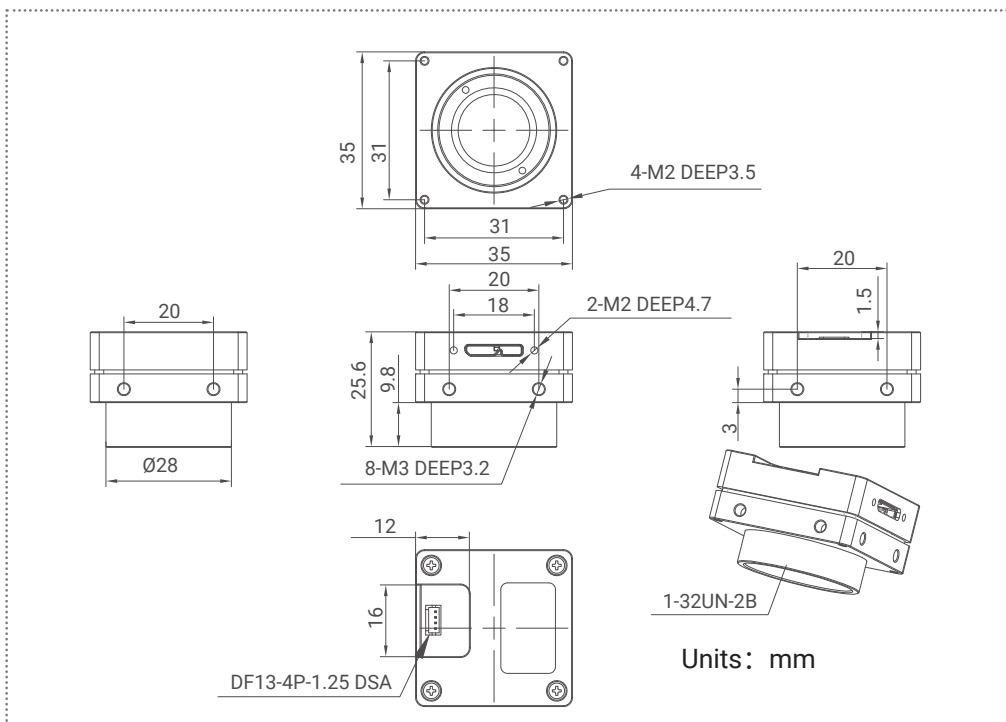

VEN-161-61U3M/C, C-mount

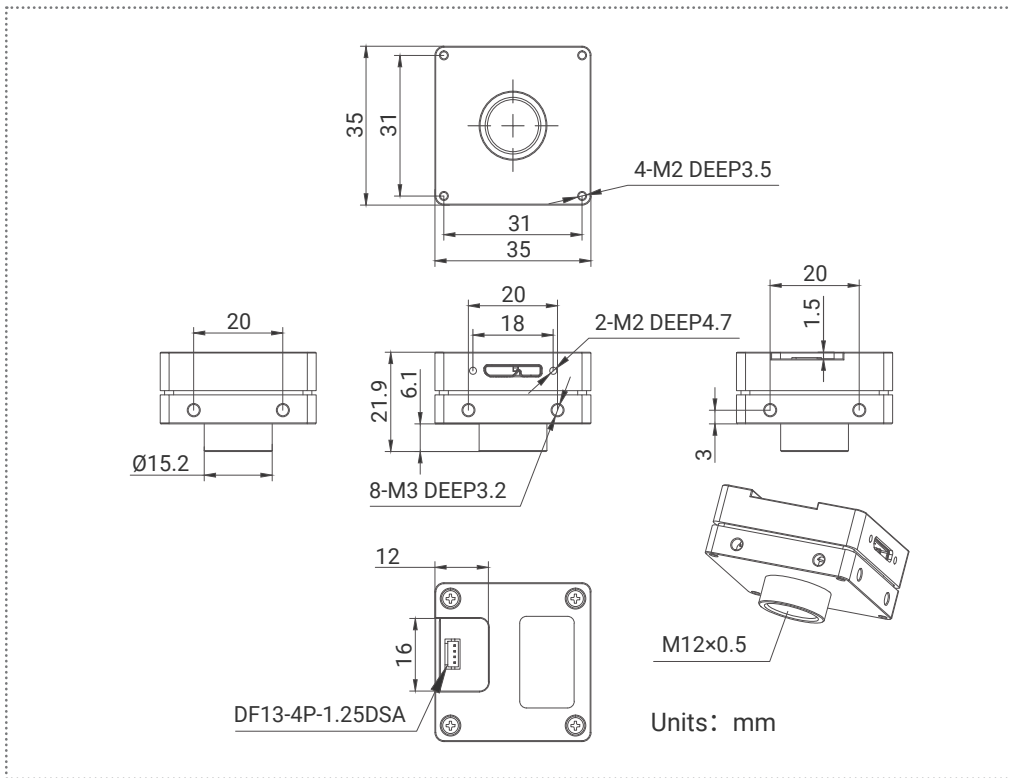

VEN-161-61U3M/C, S-mount

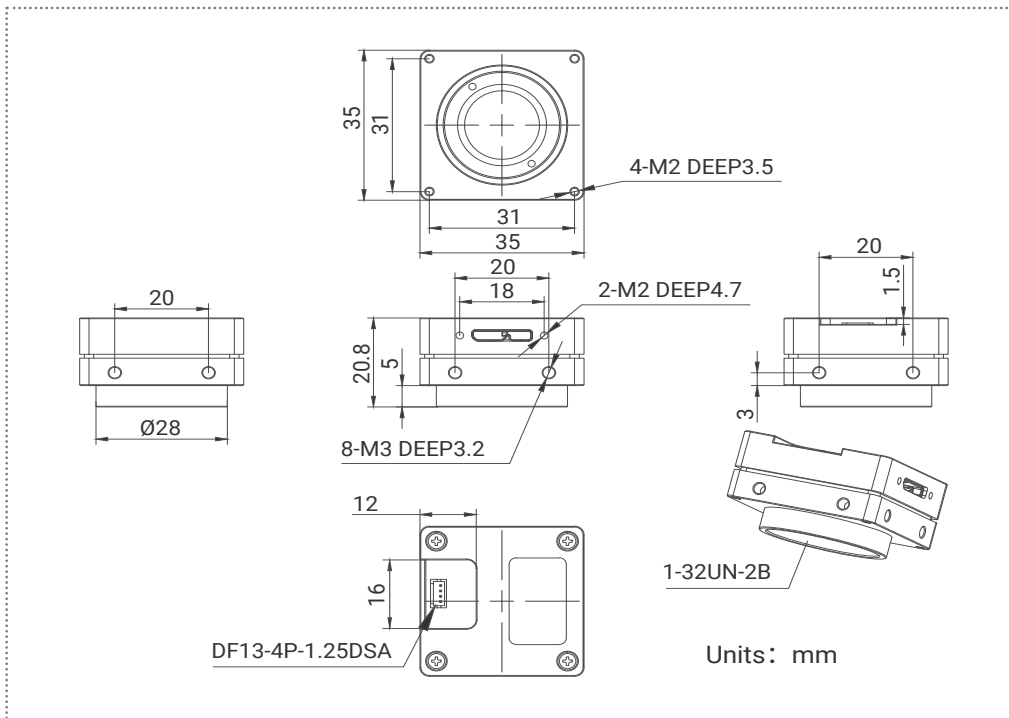

VEN-161-61U3M/C, CS-mount

China Daheng Group, Inc. Beijing Image Vision Technology Branch

12F Daheng Science & Technology Tower, No.3 Suzhou Street, Haidian District, Beijing China, 100080

Tel: +86 10 82828878

E-mail: isales@daheng-imaging.com